

DESIGN NOTES

LTC1392 Monitors System Temperature and Multiple Supply Voltages and Currents – Design Note 149

Kevin R. Hoskins and Alan Rich

Fault-tolerant systems ensure their users uninterrupted service and prevent data loss through acquisition of accurate supply voltage, load current and temperature information. By comparing this information to predetermined operating profiles, the system decides if the measured data is within nominal ranges or if a fault condition is looming. If a fault condition is imminent, the system takes corrective action before data is lost.

The measured data can also be used to establish preventative maintenance schedules. The system develops stress profiles based on operating time and the measured values of the different parameters. These profiles suggest a need for increased preventative maintenance when the measured values indicate high sustained peak operation over a given time period or a relaxed schedule during times of reduced activity.

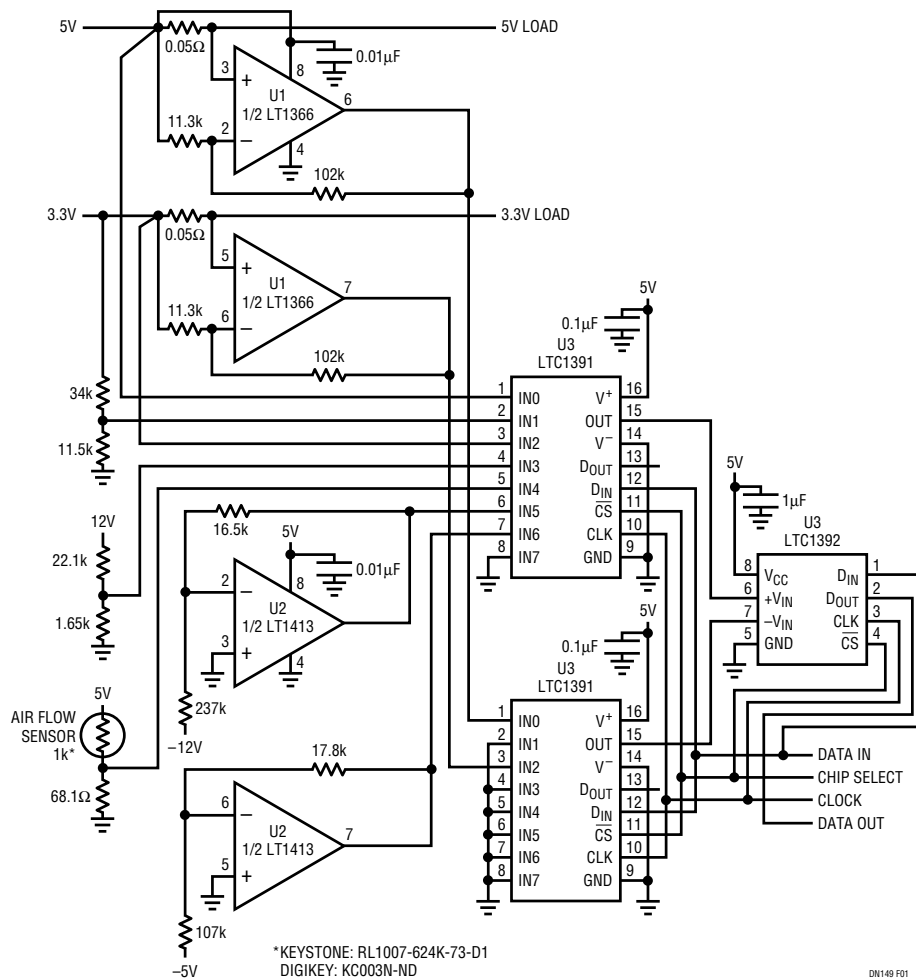

Figure 1. The LTC1392, with the Help of a Few Friends, Helps Prevent Data Loss and Down Time by Providing Feedback as it Monitors a Fault-Tolerant Computer System

The circuit shown in Figure 1 monitors the multiple supply voltages, supply currents and temperatures of a fault-tolerant system. The heart of the circuit is the LTC[®]1392. This 8-pin system monitor looks at supply voltage, load current and temperature. It operates on a single 5V (typ) supply and draws a nominal 350 μ A while converting or just 0.2 μ A when idle. It includes an onboard temperature sensor, differential sample-and-hold, bandgap reference and a 10-bit ADC. The LTC1392 communicates with a host system through a serial interface.

Multitude of Measurements

As configured, the circuit in Figure 1 monitors a system's 3.3V, \pm 5V and \pm 12V supply voltages. It also captures the 3.3V and 5V supplies' output current magnitude. Lastly, it acquires two temperatures: ambient from the LTC1392's built-in sensor and a remote from an external sensor.

The monitoring circuit selects the current, voltage and temperature signals using two LTC1391 serially programmed multiplexers. Multiple LTC1391s are programmed either by daisy-chaining a device's serial data output pin (D_{OUT}) to the data input pin (D_{IN}) of the next device or by connecting together the data input pins of each part. Daisy-chaining multiple LTC1391s works best for applications that require unique channel selection on each MUX or need simultaneous selection of different channel combinations across multiple MUXs. This latter connection allows an ADC with differential inputs to convert the difference between different combinations of signals.

Figure 1's circuit shows the connection that selects the same channel on each LTC1391. This connection simplifies the software because only one channel selection data byte is created and applied to each MUX simultaneously. By pairing the same channel on each LTC1391, the circuit converts signals that are either across the current sense resistors or ground referred. The signals across the current sense resistors are applied to the LTC1392's differential input by selecting the same channel of each LTC1391. Ground-referred signals are applied to one LTC1391 while the corresponding channel on the other LTC1391 is grounded.

The current sensing resistors in the 5V and 3.3V supply outputs are kept small, minimizing their voltage drop and dissipation. A dual LT[®]1366 op amp amplifies the small drop across the sense resistors by a gain of 10. The amplifiers' outputs are selected with the LTC1391 multiplexer and applied to the LTC1392's input. The LTC1392's inputs have a common mode input range that includes ground and the voltage applied to the V_{CC} pin. For the

0.05 Ω series resistor value shown, the full-scale current range is 2A, with a resolution of 19.5mA.

The LTC1392 measures the 5V supply voltage through the on-chip V_{CC} supply line with an accuracy of \pm 39mV over a $-40^{\circ}\text{C} \leq T_A \leq 85^{\circ}\text{C}$ range. This accuracy is guaranteed over a supply voltage monitor range of 4.5V to 6V.

The 3.3V, -5V and $\pm 12\text{V}$ are scaled and measured using the LTC1392's 1V input range. The chosen scaling factor allows for as much as 20% supply output fluctuation without exceeding the ADC's full-scale input range.

The application circuit measures ambient temperature and cooling air flow using two different temperature sensors. One of the temperature sensors is built into the LTC1392 system monitor and measures ambient temperature. The monitor's small, SO-8 size makes it unobtrusive and easily placed in tight quarters. It communicates with a host system using a serial interface that requires just three connections. Together, the small size and minimum interface allow remote placement. The LTC1392 is specified over a -40°C to 85°C temperature range with 0.25 $^{\circ}\text{C}$ /count. The output code varies from zero at -130°C to full scale at 125°C .

The second temperature sensor, a NTC 1k Ω thermistor, and a 68.1 Ω series resistor were chosen to induce self-heating in the thermistor. The thermistor is placed in a cooling fan's air stream and helps the host system, using the "wind-chill" effect, determine the fan's performance. As air moves across the thermistor, it is cooled, increasing both its resistance and voltage drop. At the same time, the voltage drop across the 68.1 Ω resistor decreases and is measured by the LTC1392. Low data values indicate that the thermistor is cooled by a properly working fan. Degradation in the fan's performance (caused by a clogged air filter, blocked air flow, a coffee cup or an LTC databook sitting on the air inlet) reduces cooling, which, in turn, decreases the thermistor's resistance. As this occurs, the voltage drop across the 68.1 Ω resistor increases, with a corresponding increase in LTC1392 output code. The 68.1 Ω resistor also sets the LTC1392's maximum input voltage of 1V to correspond to approximately 50°C . Because of many possible variations in the mechanical and physical layout of different systems, the thermistor and series resistor values may require custom selection.

 LTC and LT are registered trademarks of Linear Technology Corporation.

For literature on our Data Conversion products, call **1-800-4-LINEAR**. For applications help, call (408) 432-1900, Ext. 2453

Linear Technology Corporation

1630 McCarthy Blvd., Milpitas, CA 95035-7417 • (408) 432-1900
FAX: (408) 434-0507 • TELEX: 499-3977 • www.linear-tech.com

dn149f LT/GP 0397 185K • PRINTED IN THE USA



© LINEAR TECHNOLOGY CORPORATION 1997